



NUGGET 120 230 V / 50 Hz

SELF-CONTAINED ICE CUBE MACHINE



FEATURES CARACTERÍSTICAS

- ▶ **PRODUCE NUGGET ICE CUBES**
PRODUCE CUBITOS DE DADO O MEDIO DADO
- STIF: STRONG INOX FRAME. SOLID MACHINE STRUCTURE IN 4 COLUMNS WITH AISI 304 STAINLESS STEEL FRAME**
- ▶ **STIF: STRONG INOX FRAME. MÁQUINA CON SÓLIDA ESTRUCTURA DE 4 COLUMNAS Y CARROCERÍA EN ACERO INOXIDABLE AISI 304**
- CLEANING SWITCH: ALLOWS CIRCULATION OF WATER WITH DESCALING PRODUCT (CALCLIN OR SIMILAR) WITHOUT COOLING**
- ▶ **BOTÓN DE LIMPIEZA: PERMITE RECIRCULAR EL AGUA CON EL DESINCRUSTANTE (CALCLIN O SIMILAR) SIN REFRIGERACIÓN**
- EASI: EASY ACCESS FOR SERVICE & INSTALLATION. ALL PANELS CAN BE DISASSEMBLED SEPARATELY**
- ▶ **EASI: FÁCIL ACCESO A CUALQUIER PUNTO YA QUE TODOS LOS PANELES PUEDEN SER DESMONTADOS DE FORMA INDEPENDIENTE**
- STRONGEST DOOR OPENING SYSTEM PATENTED BY ITV. DOOR MADE IN STAINLESS STEEL AISI 304**
- ▶ **SISTEMA DE APERTURA MÁS ROBUSTO DEL MERCADO. PUERTA HECHA EN ACERO INOXIDABLE. SISTEMA DE APERTURA Y AMORTIGUACIÓN PATENTADO POR ITV**
- SMART FRONT VENTILATION SYSTEM (SFVS) ALLOWS BUILT-IN INSTALLATION OF THE UNIT**
- ▶ **EL SISTEMA INTELIGENTE DE VENTILACIÓN FRONTAL (SFVS) PERMITE LA INSTALACIÓN EMPOTRADA DE LA MÁQUINA**
- ELECTRONIC CONTROL THAT ENHANCES THE PERFORMANCE OF THE MACHINE AND ALLOWS IT TO ADAPT TO EXTREME CLIMATES**
- ▶ **CONTROL ELECTRÓNICO QUE MEJORA EL FUNCIONAMIENTO DE LA MÁQUINA Y LE PERMITE ADAPTARSE A CLIMAS EXTREMOS**
- NATURAL GAS R290 WITH VERY LOW GLOBAL WARMING POTENTIAL WHICH ALSO REDUCES THE ENERGY CONSUMPTION**
- ▶ **GAS NATURAL R290 CON MUY BAJO ÍNDICE GWP EL CUAL TAMBIÉN REDUCE EL CONSUMO ENERGÉTICO**
- LED ON/OFF SWITCH / PCB MOUNTED AT THE BOTTOM**
- ▶ **INTERRUPTOR LED DE FUNCIONAMIENTO ON-OFF/ PLACA ELECTRÓNICA MONTADA EN LA PARTE INFERIOR**
- ▶ **TROPICALIZED MACHINES (T CLASS)**
MÁQUINAS TROPICALIZADAS (CLASE T)



		(Kg)	(Kg)	(Kg)	(Kg)	(mm)	(mm)	
NUGGET 120 A		120	108	40	40	Width 738	Width 800	NUGGET 1,1gr 8% HUM
NUGGET 120 W		-	-			Depth 700	Depth 670	
						Height 822*	Height 995	

* WITH LEGS 937/987 CON PATAS 937/987

ACCESSORIES ACCESORIOS

INCLUDED



WATER INLET HOSE
MANGUERA DE ENTRADA DE AGUA



WATER OUTLET HOSE
MANGUERA DE DESAGÜE



4 HEIGHT ADJUSTABLE LEG KIT
KIT 4 PATAS ALTURA REGULABLE



WATER INLET FILTER GASKET
JUNTA DE FILTRO DE ENTRADA DE AGUA



MEDIUM SCOOP
PALA MEDIANA

NOT INCLUDED (OPTIONAL)



ANTI-LIMESCALE FILTER
FILTRO ANTICAL



PARTICLE FILTER
FILTRO ANTIPARTICULAS



ANTI-CHLORINE FILTER
FILTRO ANTICLORO



ANTI-LIMESCALE + ANTI-CHLORINE FILTER CS111
FILTRO ANTICAL + ANTICLORO CS111



C4 WATER SOFTENER
DESCALCIFICADOR C4



CALKLIN 50 CLEANER
PRODUCTO ANTICAL



4 WHEELS KIT
KIT 4 RUEDAS

SIDE VIEW
VISTA LATERAL

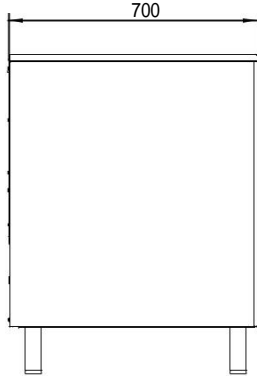

FRONTAL VIEW
VISTA FRONTAL

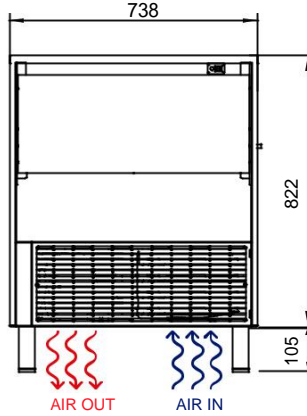

REAR VIEW
VISTA TRASERA

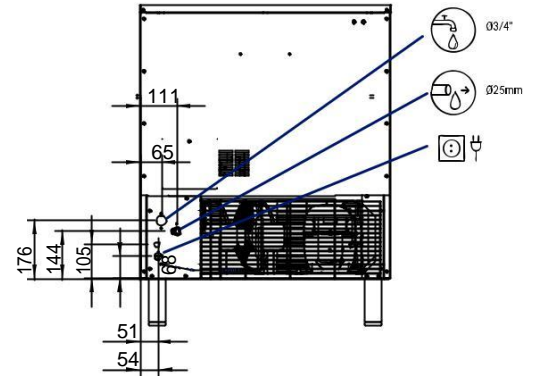

* All measurements in mm.
* Todas las cotas en mm.

OPERATING CONDITIONS CONDICIONES DE OPERACIÓN

PRODUCTION 50Hz PRODUCCIÓN 50 Hz

±10% V
 10°C/43°C
 5°C/38°C
 1 bar/6 bar
 144/288 Ice cubes/cycle
 R 290
 24 H

V	Hz	ph
230	50	1N

MODELS
MODELOS

	ASHRAE CONDITIONS CONDICIONES ASHRAE	(W) (BTU/h)	(W) 43°C	(n.) (mm ²)	FUSE	(Kwh)	(l/h)	(W) (BTU/h)	(Kg)	(Kg)	(m ³)
NUGGET 120 A		1050	3	1,5	16	15,2	6,3 7,3	1.363 4.648	98	102	0,66
NUGGET 120 W		-	-	-	-	-	-	-	-	-	-



Subject to certain limitations and exclusions. Only spare parts. Sujeto a limitaciones y exclusiones. Solo piezas de repuesto.